

# Deluxe Pizza Cutter Kit

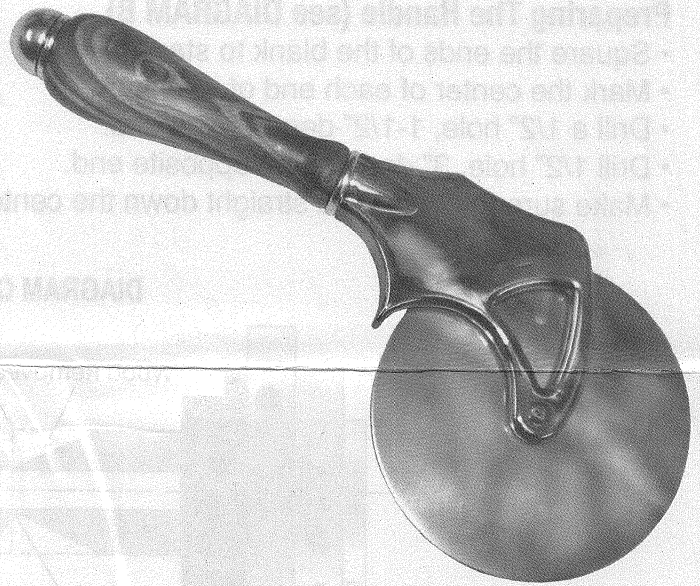

### Kit Features:

- Heavy Duty
- 4" Diameter Deluxe Cutter
- Stainless Steel Components

### Required Accessories:

- Drill Bit - 1/2" #PKDB12
- 60° Live Center
- Woodworking Chuck (4 jaw chuck)
- Parting Tool
- 2 Part Epoxy Glue
- Wood Required: 1-1/2" Square x 6" Long

DIAGRAM A / PARTS LAYOUT

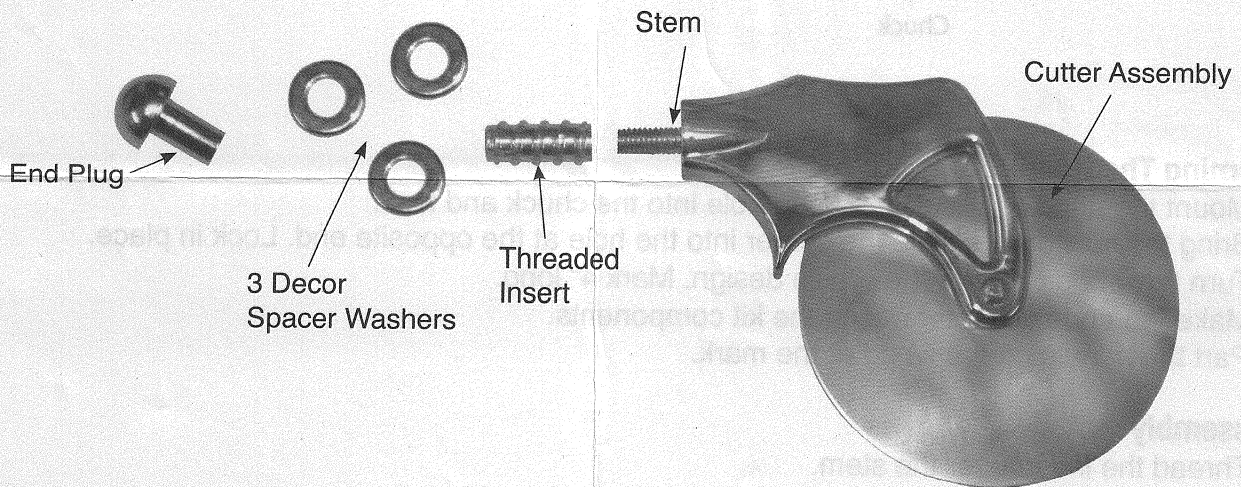
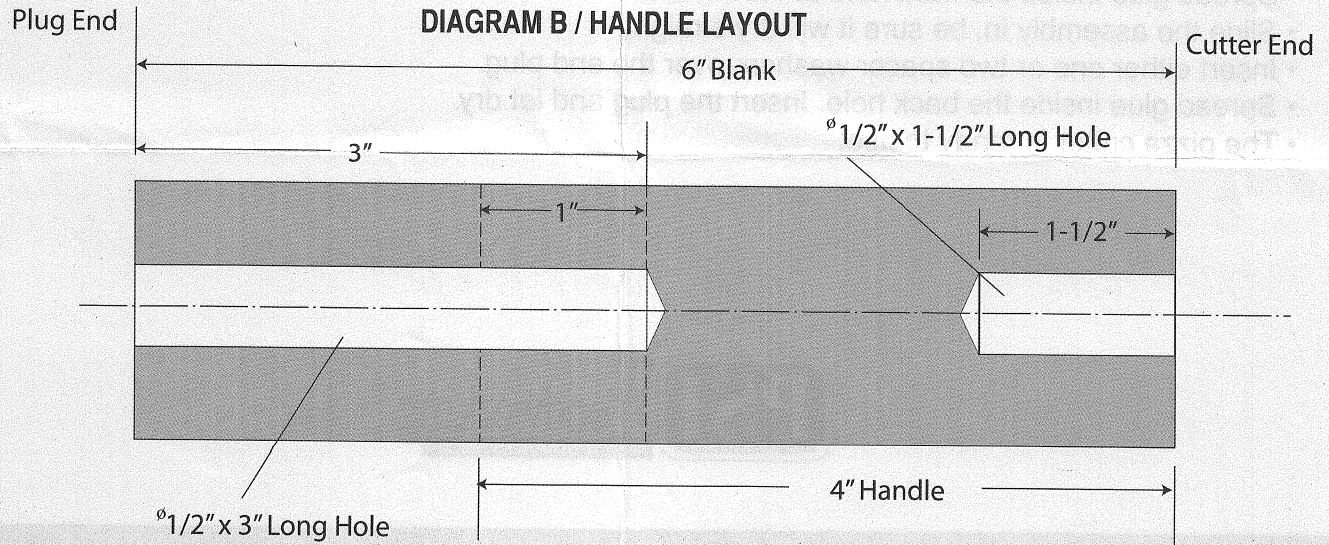

DIAGRAM B / HANDLE LAYOUT



## Preparing The Handle (see DIAGRAM B)

- Square the ends of the blank to start.
- Mark the center of each end of the blank.
- Drill a 1/2" hole, 1-1/2" deep at one end. (1/2" is loose fit. Drill to 31/64" for hardwood, 15/32" for softwood.)
- Drill 1/2" hole, 3" deep at the opposite end. (drill this one to 1/2" as stated here.)
- Make sure the holes are straight down the center.

## DIAGRAM C / TURNING THE HANDLE

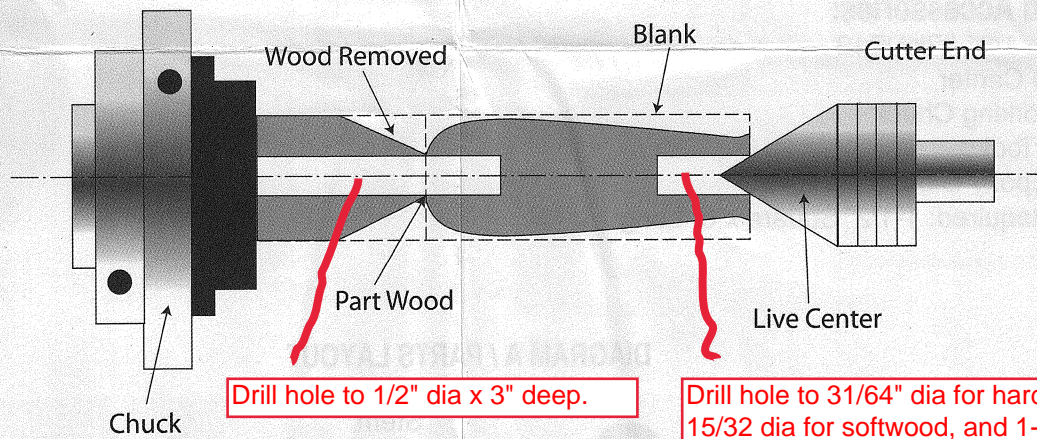

## Turning The Handle

- Mount the handle, with the 3" deep hole into the chuck and lock.
- Bring the tailstock in, slide the center into the hole at the opposite end. Lock in place.
- Turn the wood down to the profile design. Mark 4" long. (to 13/16" O.D. at cutter end)
- Make the ends diameter match the kit components.
- Part the handle off the wood at the mark.

## Assembly

- Thread the insert over the stem.
- Place either one or two spacer washers on the threaded insert.
- Spread glue inside the front hole at the handle.
- Slide the assembly in, be sure it will dry straight.
- Insert either one or two spacer washers over the end plug.
- Spread glue inside the back hole. Insert the plug and let dry.
- The pizza cutter is ready to use.

